

Shell And Tube Heat Exchangers

Tailor-made heat exchanger solutions for applications in all fields.

Introduction

The Ipros Shell and Tube Heat Exchanger is a premium industrial product with flexible design and manufacturing capabilities which exceed clients' requirements.

Standard design offers short delivery time, reliability, and an excellent price to performance ratio.

Special designs are available on request, like floating heads, higher pressures and temperatures, different connection standards, different materials, better surface finish, passivation, and much more. For more information please contact Ipros's Heat Exchangers division.

Field of application:

Pharmaceutical and Biopharmaceutical Industry
Chemical industry
Food and Beverage Industry
Energy/Power sector, HVAC, etc.

Design:

Designed according to the EN 13445 standard and the (PED) 97/23/
EC pressure equipment directive
Different design for different application
U-tube or straight
Single-pass or multi-pass

Working conditions:

Pressure: up to 10 bar
Temperature: up to 180° C
Flow Rate: up to 30.000 l/h
Note: Higher pressures, temperatures and flow rates available on demand.

Tube material:

Werkstoff Nr. 1.4435 (AISI 316L) - seamless
Werkstoff Nr. 1.4404 (AISI 316L), 1.4301 (AISI 304) - TIG welded
Werkstoff Nr. 1.4301 (AISI 304), 1.4571 (AISI 316 Ti) - seamless

Sealing:

PTFE, NBR, EPDM, Viton, etc.
Seals can be FDA approved.

Dimensions:

Length: from 750 to 3000 mm
Shell diameter: from DN80 to DN400
Connection sizes: from DN10 to DN250
Note: Different sizes available on demand.

Mounting:

Vertical or horizontal

Connections:

Flange DIN EN 1092
Tri-clamp DIN 32676
Food industry fitting DIN 11851
Aseptic connection DIN 11864

Insulation:

Available with or without insulation.
Heat insulation: Glass wool DIN EN 4102-1 A2.
Cooling insulation: PU-foam DIN EN 4102-1 B2
Thickness: from 20 to 80 mm

Welding:

According to EN ISO 15614-1, EN 287-1

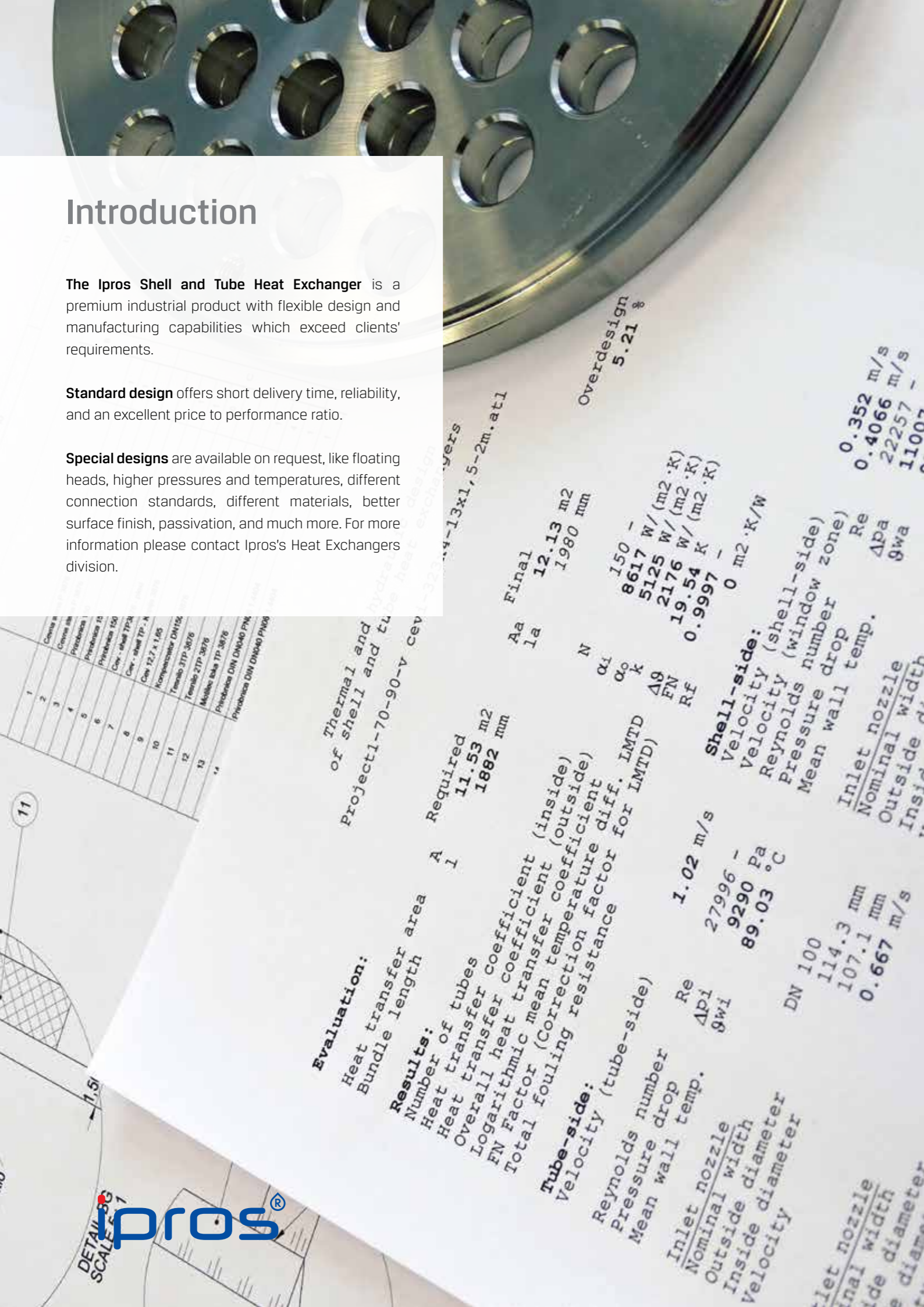

PhTH / PhTC Shell and Tube Heat Exchangers

Ipros Pharma Shell and Tube Heat Exchangers are specially designed to meet the highest hygienic standards for the pharmaceutical industry – GMP (Good Manufacturing Practice). They can be used for heating, cooling, and tempering pharmaceutical products. Pharma Exchangers are perfect for CIP systems, water for injection, purified water, etc.

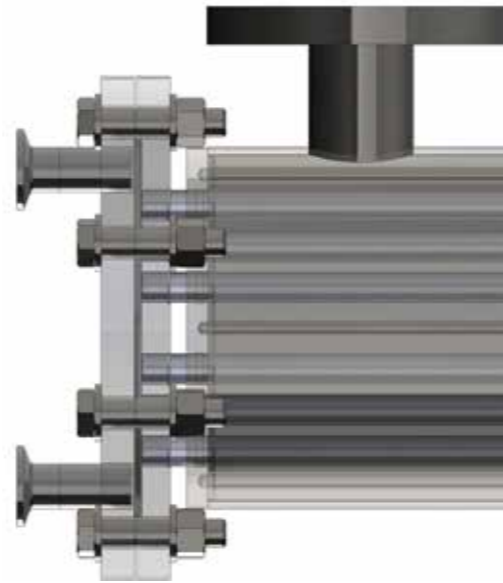

Tube material: Werkstoff Nr. 1.4435 (AISI 316L) - seamless

Sealing: EPDM, PTFE
Seals are FDA approved

Product connections: Tri-clamp DIN 32676
Aseptic connection DIN 11864
Flange DIN EN 1092
Food industry fitting DIN 11851

Service medium connections: Flange DIN EN 1092,
Tri-clamp DIN 32676,
Food industry fitting DIN 11851

Surface finish: Electro polished Ra<0.4µm – in contact with the product.

Leakage: Double tube sheet ensures that service media never mix with the product – no risk of cross-contamination.
Working principle: The product flows through a bundle of seamless tubes while the service medium flows in a shell around these tubes. The service medium is sealed in the shell by the first tube sheet while the second tube sheet seals the product inside tube bundle. In the event of a leak, the leakage of either fluid is easily visually detected.



Draining: Pharma exchangers are fully drainable on the product side

Certificates: Inspection certificate 3.1 DIN EN 10204 for all material in contact with product

Working conditions: Pressure: up to 10 bar
Temperature: up to 180° C
Flow Rate: up to 30.000 l/h
Note: Higher pressures, temperatures and flow rates available on demand

Dimensions: Length: from 750 to 3000 mm
Shell diameter: from DN80 to DN400
Connection sizes: from DN10 to DN250
Note: Different sizes available on demand.

Mounting: Vertical or horizontal

Insulation: Available with or without insulation.
Heat insulation: Glass wool DIN EN 4102-1 A2
Cooling insulation: PU-foam DIN EN 4102-1 B2
Thickness: from 20 to 80 mm

Welding: According to EN ISO 15614-1, EN 287-1

Design: Designed according to the EN 13445 standard and the (PED) 97/23/EC pressure equipment directive
U-tube or straight
Single-pass or multi-pass



FBTH / FBTC Shell and Tube Heat Exchangers

Ipros Beverage Shell and Tube Heat Exchangers are designed for use in food and beverage industry. They can be used for heating, cooling, and tempering low viscosity liquids. Beverage exchangers are suitable for milk, beer, juice, CIP, and more.

Tube material:	Werkstoff Nr. 1.4404 (AISI 316L), 1.4301 (AISI 304) - TIG welded Werkstoff Nr. 1.4301 (AISI 304), 1.4571 (AISI 316 Ti) - seamless
Surface finish:	Ra<0.8µm, (weld - Ra<1.6µm) – in contact with the product.
Sealing	PTFE, EPDM, NBR, etc.
Connections:	Food industry fitting DIN 11851 Flange DIN EN 1092 Tri-clamp DIN 32676 Threaded connection DIN ISO 228
Certificates:	Inspection certificate 2.2 DIN EN 10204 for all material in contact with product.
Options:	Draining - Beverage exchangers can be fully drainable on the product side. Leakage - Double tube sheet ensures that service media never mix with the product.



Working conditions:

Pressure: up to 10 bar
Temperature: up to 180° C
Flow Rate: up to 30.000 l/h
Note: Higher pressures, temperatures and flow rates available on demand

Dimensions:

Length: from 750 to 3000 mm
Shell diameter: from DN80 to DN400
Connection sizes: from DN10 to DN250
Note: Different sizes available on demand.

Mounting:

Vertical or horizontal

Insulation:

Available with or without insulation.
Heat insulation: Glass wool DIN EN 4102-1 A2
Cooling insulation: PU-foam DIN EN 4102-1 B2
Thickness: from 20 to 80 mm

Welding:

According to EN ISO 15614-1, EN 287-1

Design:

Designed according to the EN 13445 standard and the (PED) 97/23/EC pressure equipment directive
U-tube or straight
Single-pass or multi-pass



InTH / InTC Shell and Tube Heat Exchangers

Ipros Industrial Shell and Tube Heat Exchangers are designed for use in chemical and power industry. They are suitable for water, steam, glycol, thermal and lube oils, etc.

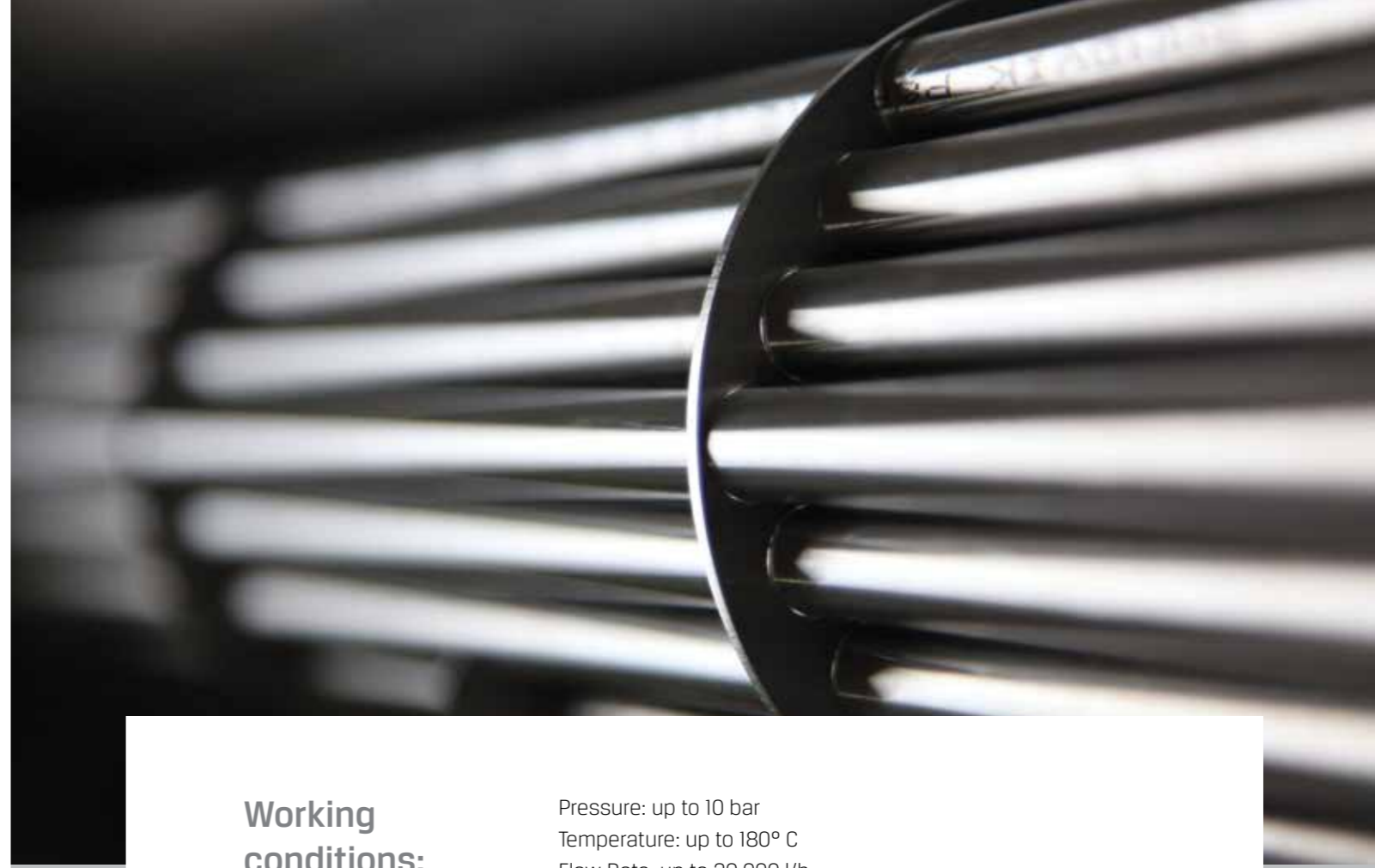

Tube material: Werkstoff Nr. 1.4404 (AISI 316L), 1.4301 (AISI 304) - TIG welded
Werkstoff Nr. 1.4301 (AISI 304), 1.4571 (AISI 316 Ti) - seamless

Surface finish: Up to Ra$0.8\mu\text{m}$, (weld - Ra$1.6\mu\text{m}$) - in contact with the product

Sealing: PTFE, NBR, EPDM, etc.

Connections: Food industry fitting DIN 11851
Flange DIN EN 1092
Tri-clamp DIN 32676
Threaded connection DIN ISO 228

Certificates: Inspection certificate 3.1 DIN EN 10204 for all material in contact with product..

Working conditions:

Pressure: up to 10 bar
Temperature: up to 180° C
Flow Rate: up to 30.000 l/h
Note: Higher pressures, temperatures and flow rates available on demand

Dimensions:

Length: from 750 to 3000 mm
Shell diameter: from DN80 to DN400
Connection sizes: from DN10 to DN250
Note: Different sizes available on demand.

Mounting:

Vertical or horizontal

Insulation:

Available with or without insulation.
Heat insulation: Glass wool DIN EN 4102-1 A2
Cooling insulation: PU-foam DIN EN 4102-1 B2
Thickness: from 20 to 80 mm

Welding:

According to EN ISO 15614-1, EN 287-1

Design:

Designed according to the EN 13445 standard and the (PED) 97/23/EC pressure equipment directive
U-tube or straight
Single-pass or multi-pass



Our service team offers our customers:

- Ongoing maintenance and servicing
- Spare parts management
- Correct disassembly for inspection
- Condition assessment
- Digital Measurement
- Channel head replacement
- Bundle replacement
- Tube expanding / rolling
- Cleaning and passivation
- Detailed service and maintenance documentation

Ipros's service team has developed extensive expertise in the design, fabrication and maintenance of shell & tube heat exchangers and offer a total life-cycle heat exchanger service.

To enhance productivity of your process line, Ipros offers preventive maintenance programs ranging from scheduled parts over on-site inspection, service and testing to complete re-conditioning at Ipros Service station.

We have adopted a high-tech approach and invested in the best equipment available to ensure consistent, high quality and cost efficient outputs, and established a dedicated workshop with highly trained staff to specialise in heat exchanger work.

We are trusted by the following companies, among others:

- Hospira, HR
- Krka, SLO
- Sandoz, SLO
- Teva, HR
- Sandoz, RO
- Sandoz, PL
- Galenika, SRB
- TE TO Kostolac, SRB
- Gostol, SLO
- Lactalis, SLO
- Fresenius Medical Care, SRB
- Bergenbeer, RO
- Helios, SLO
- Belinka (Solvay), SLO
- Končar GIM, HR
- Bundge, RO
- Komunala Velenje, SLO



SLOVENIA
Ipros d.o.o.

Cesta v Gorice 30
1000 Ljubljana
Slovenija

Boris Dersek
T: +386 1 200 26 20
F: +386 1 423 18 24
E: boris.dersek@ipros.si
www.ipros.si



CROATIA
Ipros – representative office CRO

Milanovačka 14
10090 Zagreb
Republika Hrvatska

Vjekoslav Piljek
T: +385 1 3483 114
F: +385 98 356 349
E: vjekoslav.piljek@ipros-hr.com
www.ipros.si



MACEDONIA
ECOTIP Ltd.

ul.Orce Nikolov 190-3/5
1000 Skopje
Macedonia

T: +389 (2) 3176 920; 3176 907
F: +389 (2) 3177 206
E: info@ecotip.com.mk
www.ecotip.com.mk



SERBIA
Ipros – representative office SRB

Majevička 5
21000 Novi Sad
Srbija

Dragan Brenesel
T/F: +381 21 403 242
M: +381 63 513 819, +386 59 233 162
E: dragan.brenesel@ipros-rs.com
www.ipros.si



ROMANIA
Ipros – representative office RO

Drumul Ciorogarla, 159, sect. 6.
Bucharesti
Romania

Popa Alin Daniel
T/F: +40 21 380 13 30
M: +40 748 06 07 08
E: popa.alin@ipros-ro.com
www.ipros.si



POLAND
Craftech

Ul. Szybowcowa 70/5
54-130 Wrocław
Poland

Łukasz Berbeć
T: +48 71 723 02 94
F: +48 71 723 01 51
M: +48 667 344 377
E: info@craftech.pl
www.craftech.pl