

Technical Datasheet

MASO-SINE-PUMP SPS 2“



Operating Principle

Minimal rotating parts ensure ease of maintenance and the sinusoidal shape of the rotor creates the „chambers“ for product movement. With every revolution of the pump the four „chambers“ massage the product through the pump with no mechanical stress.

The scraper divides the suction and pressure sides and also forms the seal. In addition, it forces CIP fluids into all areas of the housing to ensure complete cleaning. It should be noted that alternative materials for scrapers are available, to suit different applications.

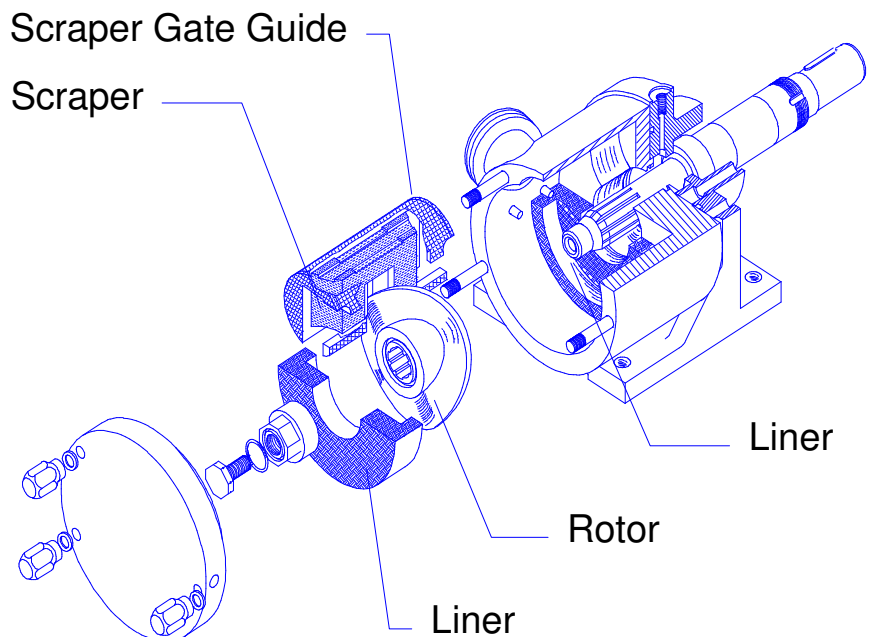

Materials of Construction

Rotor:	Stainless Steel / hardened / with titanium coating
Housing:	Stainless Steel
Scraper:	MASOTRONIC
Liners:	Stainless Steel, MASOTRONIC
O-Ring:	Buna, EPDM, VITON, TEFLON
Shaft:	Stainless Steel
Lip Seal:	Buna, PTFE, VITON
Bushing:	Cast Iron
Front Bushing	MASOTRONIC, Carbon

Seal Systems

Single lip seal system
Triple lip seal system
Single mechanical seal
Double mechanical seal
Seals on request

Connections

German milk fitting DIN 11851
Flange DIN 2633/2635
Industrial thread
Inch
SMS
Tri-Clamp
RJT
ANSI
Special connection upon request

Heating - Cooling

Heating or cooling for Housing
Front cover heating or cooling
Connections heating or cooling

Flushing of the seal

Dynamic flushing
Static flushing

Drives

Variable speed drives/elec. speed variation
Helical gear motor
Helical gear motor with frequency inverter
Drives on request
Without drives
Explosion proofed drives

Base plates

Tube style base plate (stainless steel) with adjustable feet and compensators
Base plate with wheels and brakes
Special construction upon request

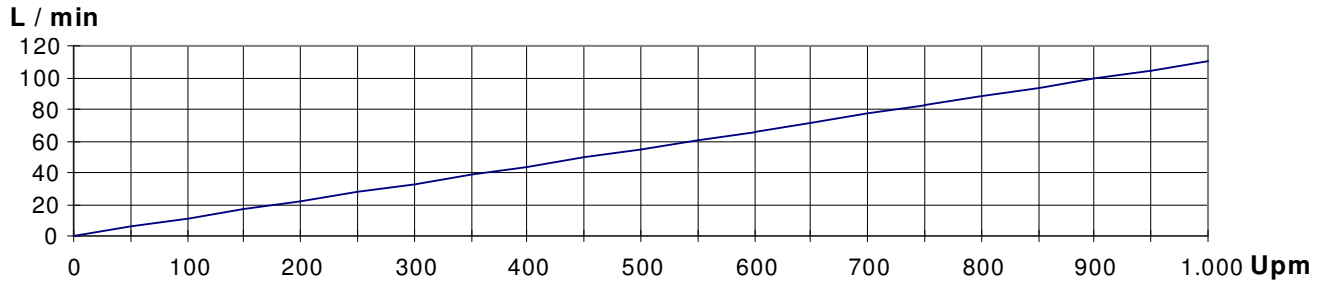

Speed
max. 1000Upm

Temperature
max. 140°C
(depending on specification)

Suction
max. 0.9 bar

Particle sizes
max. 18mm

Capacity
0.11 Liter / revolution
max.6600 L/h in continuous
operation with water and 0 bar
pressure

Pressure
max. 15 bar

Viscosity
over 1.000.000 CP

Cip-Cleaning
fully suitable for CIP
CIP-cleaning

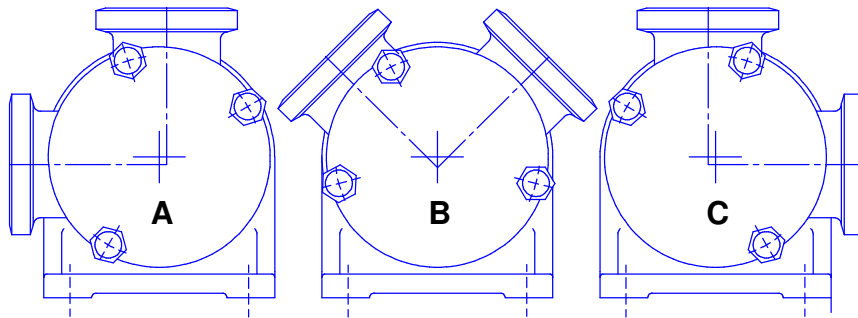

**Possible connection
positions**

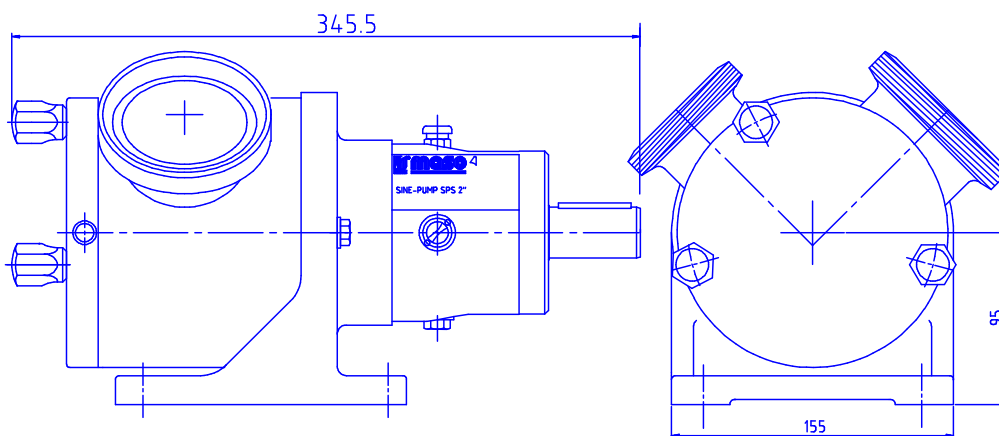

Weight
ca.20 kg
(without drive)

Dimensions

If there are any questions, then please get in touch with us

MASO Process-Pumpen GmbH • Steinbeisstr. 3 • 74360 Ilsfeld • Postfach 100

☎ ++7062 / 9560-0 • Fax ++7062 - 64593

★ A German quality product ★

(Changes without notice)