

CONCITHERM Plate Evaporators

CONCITHERM CT 193

The large Evaporator Plate

Concitherm stands for an efficient and true free flow plate heat exchanger with the highest performance. Optimised plate design enables wide flow gaps with few contact points even with 3m² per laser welded cassette.

Low pressure losses in the heat exchanger avoid an intermediate pump, hence reduce installation and operational costs. Furthermore, in comparison to conventional tube evaporators, Concitherm offers an almost 100% higher heat transfer coefficient.

Concitherm plate evaporators can serve as boosters to conventional evaporators as well as in stand-alone applications within the sugar, food and chemical industries. Additionally it is also suited for waste water treatment.



Advantages

3 m² heat transfer surface per laser welded cassette enables:

- large evaporator duties
- compact unit-design
- short residence time
- less gaskets

Free flow gaps ensure:

- constant juice flow into the vapour chamber
- low pressure drops
- high heat transfer coefficient (OHTC-value)

Large inlet/outlet areas for vapours result in:

- high evaporation capacity
- lower investment costs, if used as a booster to a Robert's evaporator

Technical Data

CONCITHERM CT 193

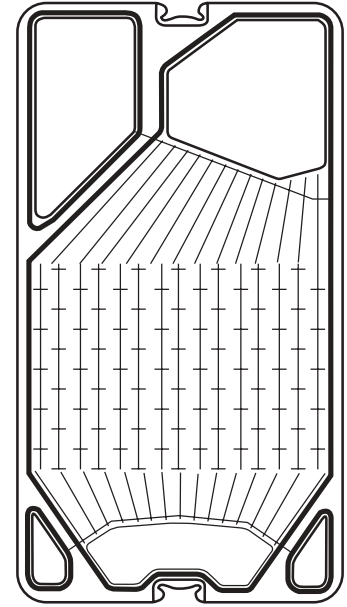
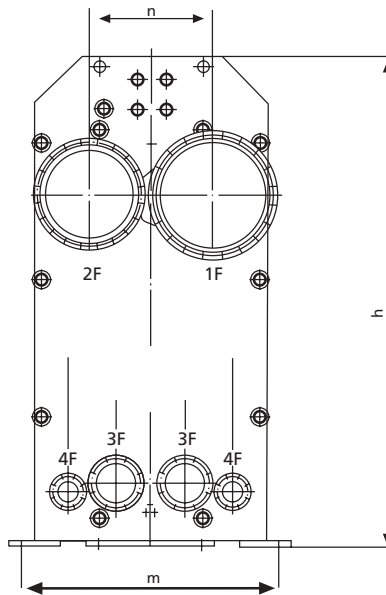
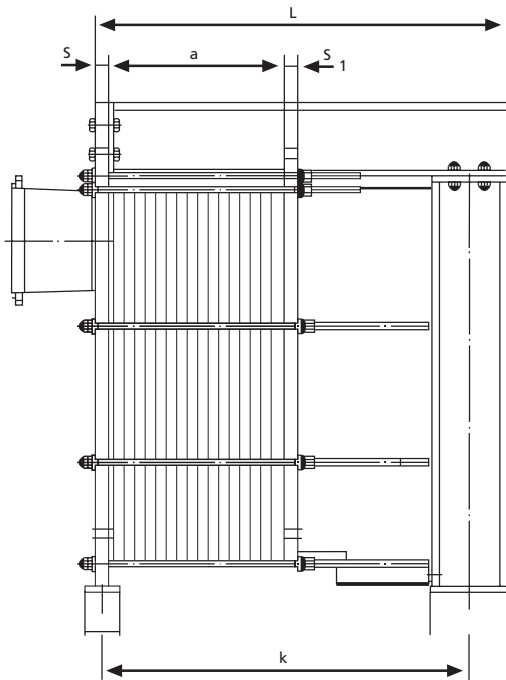

Connections: 1F – DN 600 mm 3F – max. DN 150 mm
 2F – DN 500 mm 4F – max. DN 100 mm

Full programme throughout the process

The range of GEA Ecoflex plate heat exchangers is diversified as the production stages in the sugar industry. Our range includes a wide selection of both model sand materials, i.e. the suitable component for every single stage of the process. Tailor-made for your specific needs and your specific plant.

VARITHERM – for variable applications of any size variable in performance, design and material selection

FREE FLOW – easy treatment of difficult media designed for viscous, fibrous and solid-loaded media

NT – an optimised plate design requires less heat transfer surface for the same performance

EVAPplus – a fully welded gasket free falling-film evaporator, especially suitable for the sugar industry

GEA Ecoflex GmbH

For more than 75 years, GEA Ecoflex has been developing customer-oriented and cost-optimised plate heat exchanger solutions for the following fields of application:

- HVAC
- refrigeration
- sugar
- chemical
- paper
- food
- life science
- marine
- power

Your contact:



Karl-Schiller-Str. 1–3, D-31157 Sarstedt
 Phone: +49/50 66/6 01-0
 Fax: +49/50 66/6 01-104
 www.gea-ecoflex.com
 e-mail: info@gea-ecoflex.com

The specifications contained in this printing unit are intended only to serve the non-binding description of our products and services and are not subject to guarantee. Binding specifications, especially pertaining to performance data and suitability for specific operating purposes, are dependent upon the individual circumstances at the operation location and can, therefore, only be made in terms of precise requests.